

GUARDIAN OWNER'S MANUAL

For Installation, Operation and Maintenance

MODEL 1384-B

Wet Chemical Extinguisher Unit

UL FILE NO. EX 3940

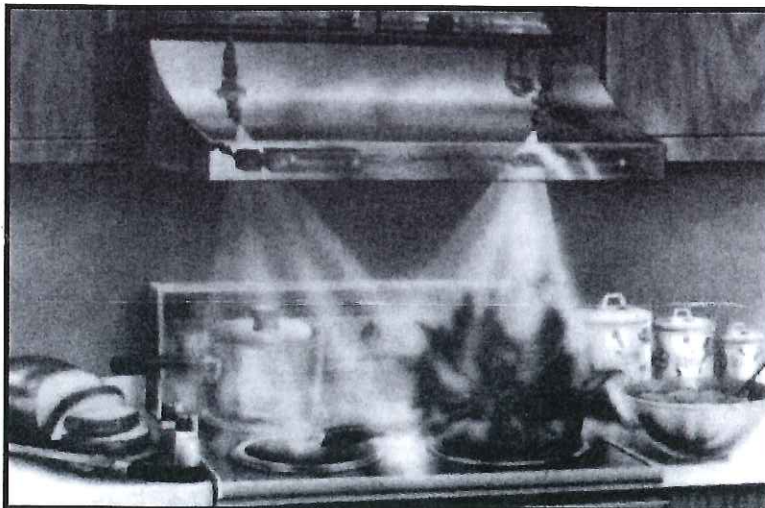

PATENTED



Guardian Safety Solutions International, Inc.

71758-B

8701 John Carpenter Freeway Suite 230 Dallas, Texas 75247

MAY 1, 2011

INTRODUCTION

There exist a variety of reasons for cooking grease fires, but most reasons involve unattended cooking accidents. Here are some tips to help prevent a cooking grease fire in your kitchen.

FIRE PREVENTION TIPS:

- Never leave the kitchen when frying food.
- Use fresh cooking oil whenever possible.
- Dense smoke from the frying pan indicates cooking oil is near auto ignition-turn the burner down or off.
- Keep cooking areas clean and clear of combustibles

If you must leave the kitchen when frying food, turn the burner off or remove the pan from the burner until you return.

IN CASE OF A GREASE FIRE:

Never attempt to move a burning pan of cooking grease from the kitchen range. **DO NOT TRY TO EXTINGUISH A GREASE FIRE WITH WATER.** Call the fire department immediately. Alert other occupants and evacuate. Let your Guardian extinguish any range top fire. Wait at least 30 minutes after a cooking fire has been extinguished before approaching your kitchen range.

DEFINITIONS

WET CHEMICAL: A solution of water and potassium carbonate based chemical, potassium acetate-based chemical or a combination thereof which forms an extinguishing agent.

LISTED: Equipment or materials included in a list published by Underwriters Laboratories Incorporated (UL).

SHALL OR MUST: Indicates a mandatory requirement.

SHOULD OR MAY: Indicates a recommendation or that which is advised.

APPLIANCE: For the purpose of this manual, appliance means a residential-type kitchen range supplied by gas or electricity to power and heat range top burners.

TABLE OF CONTENTS

INTRODUCTION AND DEFINITIONS	1
GUARDIAN SYSTEM COMPONENTS	2
APPLICATION AND LIMITATION	3
CLEAN-UP AND MAINTENANCE	3
EXTINGUISHER AND BRACKET KIT COMPONENTS	4
PIPING KIT COMPONENTS	5
DETECTION KIT COMPONENTS	6
HARDWARE KIT COMPONENTS	7
INSTALLATION INSTRUCTIONS	8-11
SHUTOFFS — ELECTRIC	12
SHUTOFFS — GAS	13
ACCESSORIES	14
OPTIONAL AUDIBLE ALARM	14
OPTIONAL REMOTE MANUAL RELEASE.....	14
TROUBLESHOOTING POINTS	15

ILLUSTRATIONS

FIGURE 1 (Guardian System Components)

FIGURE 2 (Extinguisher Kit Components)

FIGURE 3 (Piping Kit Components)

FIGURE 4 (Detection Kit Components)

FIGURE 5 (Hardware Kit Components)

FIGURE 6 (Detection Kit Installation)

FIGURES 7 & 8 (Hole Locations)

FIGURE 9 (Extinguisher Kit Installation)

FIGURE 10 (Rear Corner Pulley Installation)

FIGURE 11 (Piping Kit Adjustment)

FIGURE 12 (Target Area — Detection Links)

FIGURE 13 (Target Area —Appliance Nozzles)

FIGURE 14 (Electric Contactor)

FIGURES 15 & 16 (Electric Wiring Instructions)

FIGURES 17, 18 & 19 (Pneumatic Gas Valve Assembly)

FIGURES 20, 21 & 22 (Optional Remote Manual Release)

GUARDIAN SYSTEM COMPONENTS

Each system consists of a pre-assembled extinguisher kit, piping kit and detection kit ready for installation in the kitchen cabinet and range hood over the stove.

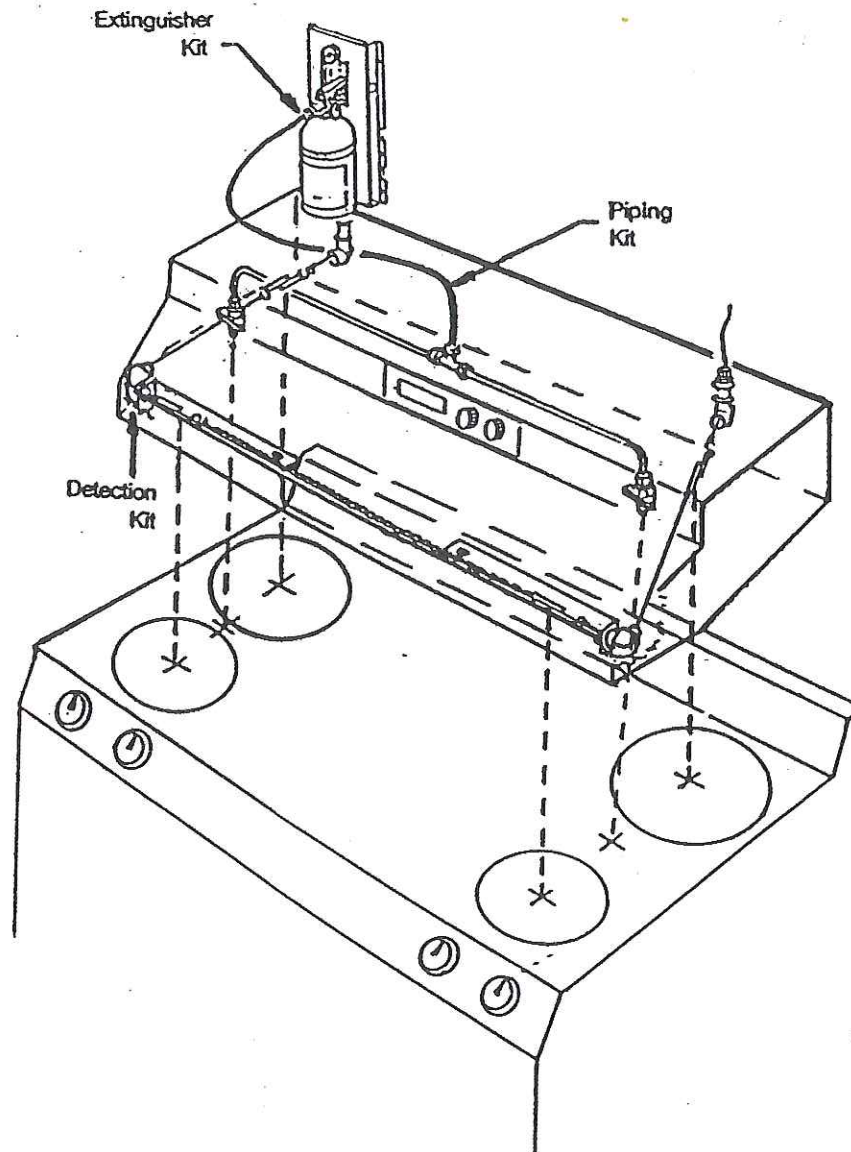

FIGURE 1

OPERATION: In event of a stove top fire, any of the four fusible or reusable links will separate, releasing the cable tension. A tension spring then automatically opens the extinguisher valve assembly, which discharges extinguishing agent through the piping system and appliance nozzles to the stove top. Simultaneously, a micro switch activates a power shut-off device and alarm or other electrical accessories.

APPLICATION AND LIMITATION

GENERAL INFORMATION

- The Guardian 1384-B is designed to fit in standard kitchen range hoods and 12" or taller kitchen cabinets above the range.
- Guardian Systems can be installed in range hoods of either a duct-free or ducted design.
- The extinguisher kit and flex hose shall be installed within a cabinet or other protected space in accordance with these instructions.
- Only components identified by part numbers in this manual are authorized for use unless expressly stated otherwise

RESIDENTIAL RANGE-TOP USE ONLY

- Guardian Systems are designed and tested for residential appliances and applications only.
- Guardian Systems are not intended for protection of commercial or restaurant-style appliances or cooking areas.
- The maximum range top cooking surface protected by the Guardian Systems is 864 square inches (a 36" X 24" range top).
- Guardian Systems are designed or intended to protect against or extinguish fires on nearby countertops or inside range ovens.
- Guardian Systems are designed or intended to protect against or extinguish fires on ranges that incorporate charbroilers, deep-fat fryers, rotisserie attachments or similar components.
- Guardian Systems are designed or intended to protect against or extinguish fires which may occur in electric or gas skillets, crock pots, deep-fat fryers or other commercial-type cooking appliances.

PACKING LIST

Check contents for missing or damaging parts (see Figures 2, 3, 4 and 5). Check fire extinguisher for proper operating pressure. Needle should point in the operable (green) zone. Report any damage or missing parts to the manufacturer before starting installation.

CAUTION:
**DO NOT REMOVE SAFETY PIN FROM
FIRE EXTINGUISHER AT THIS TIME!!!**

NOTE:

Additional equipment or components necessary to install the system in accordance with the instructions and limitations listed are to be provided by the authorized installer, if not purchased with the basic system (i.e., electrical wire, wire mold, shut-off components, etc.). Additional equipment and components may be obtained from an authorized Guardian Safety Solutions International distributor or the manufacturer.

CLEAN UP AND MAINTENANCE

After the system has discharged, disconnect electrical appliances sprayed by the chemical. For electric ranges, breaker to range should be turned off. Use rubber gloves to protect skin. Use a sponge and warm soapy water to wipe off excess chemical. A damp cloth should be used in the final cleaning process. Do not use a water vacuum type cleaner.

CAUTION:

WHEN CLEANING THE KITCHEN RANGE HOOD OR WHEN YOUR GUARDIAN SYSTEM IS REMOVED, THE SAFETY PIN SHOULD BE REINSERTED INTO THE FIRE EXTINGUISHER VALVE ASSEMBLY. TO REACTIVATE THE SYSTEM, REMOVE THE SAFETY PIN.

NOTE: Always check for proper cable tension before removing the safety pin (see installation instructions Step 11).

Monthly, check nozzles for visual signs of obstruction. Check pressure gauge. If the needle points to the "recharge" or "overcharged" zone, contact an authorized Guardian Safety Solutions International representative immediately for service.

Annually, inspect all components, including fire extinguisher unit, appliance nozzles, cable, corner pulleys, tension spring, piping and detection links (replace standard fusible links annually). Keep the Guardian system free of cooking grease residue.

Every **Twelve (12) years** empty and hydrostatically test the fire extinguisher cylinder and flexible hose assembly to the marked pressure, per NFPA 17A. Replace the liquid chemical with new agent (P/N #G-BRK). Do not combine chemicals. Replace the tension spring (P/N 48410).

NOTE: Before replacing the liquid chemical agent, the extinguisher cylinder, valve assembly, valve piping adapter, piping kit and nozzles must be thoroughly cleaned by flushing with water. It is recommended to wear approved type eye protection and rubber gloves when cleaning parts.

A complete system inspection and servicing must be accomplished immediately following a kitchen range top fire. Consult an authorized fire equipment company for service or proper procedure.

EXTINGUISHER AND BRACKET KIT COMPONENTS (P/N 1384BCYL/CHARGED & 1384BEXT/SUB)

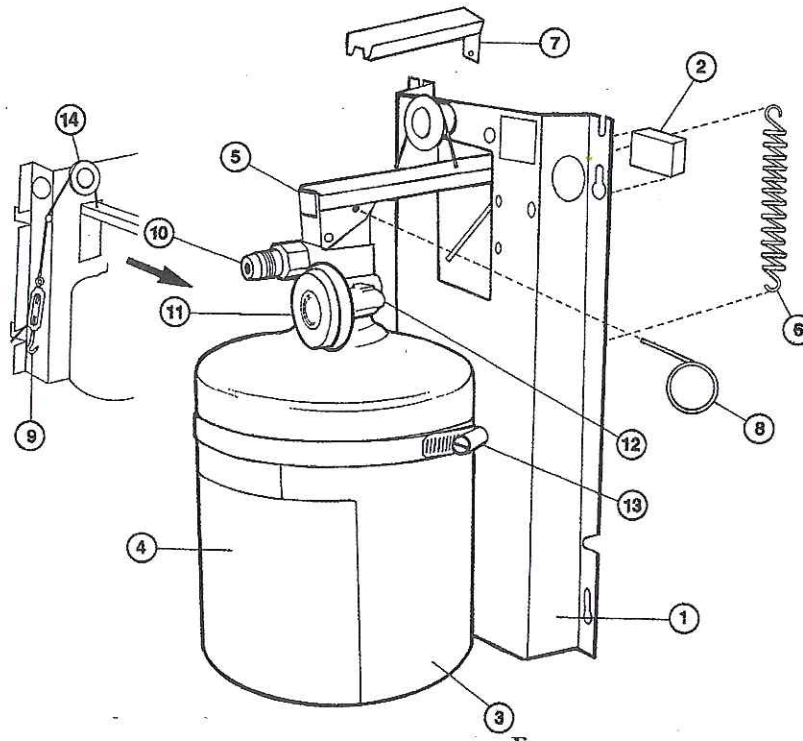

FIGURE 2

DESCRIPTION

The extinguisher kit consists of the pressurized storage cylinder for the chemical agent mounting bracket support assembly and other components identified with Figure 2.

LIMITATIONS: The extinguisher cylinder shall be installed in locations where the temperature will range between 32 ° F (0° C) and 120° F (49 ° C). Never attempt to use the fire extinguisher as a hand held portable extinguisher.

CAUTION: Serious injury could result from misuse.

THE CHEMICAL AGENT USED IN THE GUARDIAN IS NOT REGARDED AS A TOXIC MATERIAL, BUT CAN CAUSE IRRITATION IF BREATHED IN SUFFICIENTLY HIGH CONCENTRATIONS. AVOID CONTACT WITH SKIN OR EYES. IN CASE OF CONTACT, FLUSH IMMEDIATELY WITH WATER FOR 15 MINUTES. IF IRRITATION PERSISTS, CONTACT A PHYSICIAN IMMEDIATELY. CHEMICAL DEPOSITS ON ELECTRICAL CONTACTS CAN PREVENT OR REDUCE CONDUCTIVITY OF THE CONTACTS. ELECTRICAL POWER MUST BE SHUT OFF PRIOR TO TOUCHING ELECTRICAL APPLIANCES SPRAYED WITH THE CHEMICAL.

PARTS LIST DESCRIPTION

QTY

1-Series "A" Mounting Bracket (P/N 34018-SW)	1
2-Mechanical Electrical Switch (P/N PCLCD-2A)	1
3-Series "A" Extinguisher Cylinder (P/N A0515-S)	1
4-UL Label (P/N UL1 384-B)	1
5-Series "A" Valve Assembly (P/N BRHD)	1
6-Tension Spring (P/N 48410)	1
7-Handle Extension (P/N 21C/DRY/HDL- EXT)	1
8-Pull Pin, Ring Type (P/N A16235)	1
9-Cable Tension Adjuster (P/N 48888)	1
10-Flare Adaptor 3/8" X 5/8" (P/N 57500)	1
11-Pressure Gauge (P/N G303/C)	1
12-90° Pressure Elbow 900 X 1/8" (P/N 202P2-2)	1
13-Cylinder Band (P/N 2iC/1384A/30175)	1
14- Wheel Bearing Pulley (P/N 21C/KB901)	1

PIPING KIT COMPONENTS
 (P/N 2 1C-ASSY/SS PIPE)

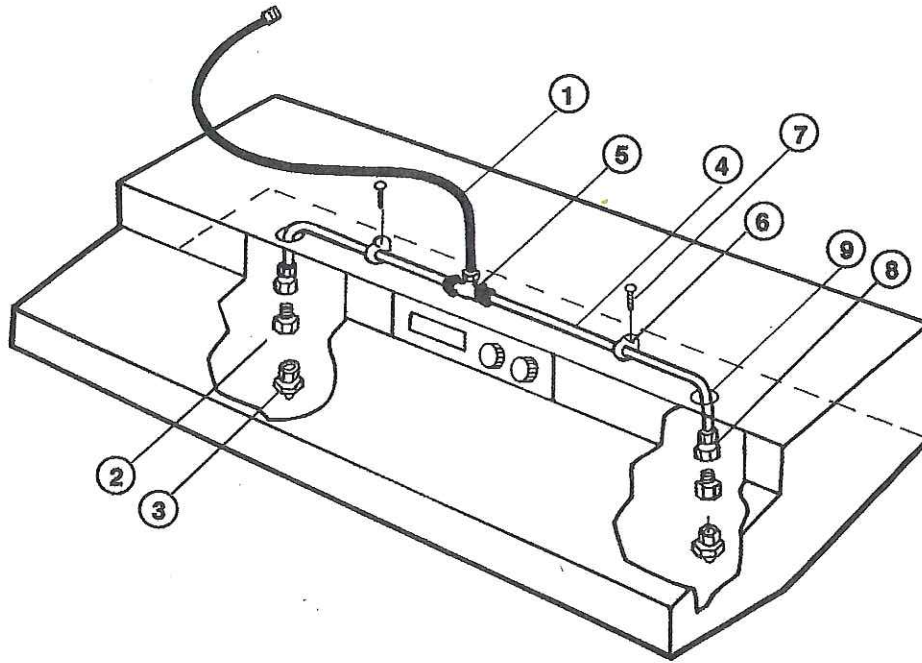

Figure 3

PIPING KIT

The piping kit consists of stainless steel tubing with a 90° bend, nozzle assemblies and other components identified with Figure 3. Hose assemblies shall not be modified. One (1) 3" diameter minimum loop can be formed in each length of hose for installations requiring unusual routing requirements.

Stainless steel tubing with a 90° bend is provided with the piping kit and shall not be modified. Tubing lengths may be reduced by cutting to fit various widths and configurations of range hoods, however, overall dimensions must not exceed the maximum lengths specified in this manual.

PARTS LIST

DESCRIPTION	QTY
1-Flex Hose ¼" X 20" (P/N HOSE-57205)	1
2-Nozzle Swivel Assembly ¼" (P/N 36275)	2

PARTS LIST (CONT'D)

DESCRIPTION	QTY
3-Appliance Nozzle Assembly (PN 1/4TGI)	2
4-Stainless Steel Tubing, 3/8" 90° (P/N SSTUB-035-8B)	2
5-Compression Tee 3/8" (P/N 48410)	1
6-318" Saddle Clamp (P/N CLAMP-i 095-APP)	2
7-Clamp Screw, #8 X 1" (P/N 48090)	8
8-Compression Female, 3/8 x ¼" (P/N FEML-64GBIJS)	2
9-Plug Flush Trim 7/8" (P/N Trim-i 7500)	2

DETECTION KIT COMPONENTS

Standard Electric P/N 21C/F-ELC/DET ASSY
Standard Gas P/N 21C/F-GAS/DET ASSY

Reusable Electric P/N 21C/R-ELC/DET ASSY
Reusable Gas P/N 21C/R-GAS/DET ASSY

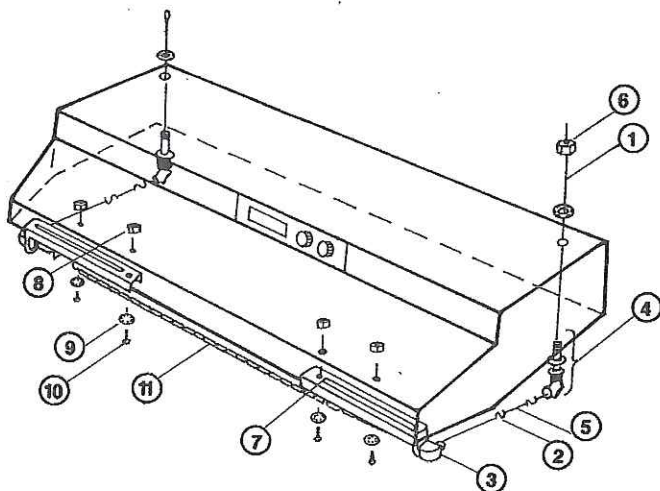

FIGURE 4

APPLICATION AND LIMITATION

The minimum number of links required is determined by the number of surface elements and the range top. Normally, four (4) links are required and provided with each Guardian unit. However, a maximum of two (2) additional links may be added to the system, provided the minimum separation distances are maintained as specified in this manual.

For applications where the maximum ambient temperature exceeds the rating for the 165° F link used for electric ranges, a higher rated link should be used. A variety of temperature ratings are available ranging from 160° F — 360° F depending on the maximum ambient temperature recorded under the range hood.

(Allowable Type of Range Top: Gas or Electric)

NOTE: The term “reusable” is defined as the acceptability of the bi-metal link to be tested using a moderate application of heat from a heat gun. Once the link is tripped, it may be reset. Links exposed to a fire shall be replaced.

DETECTION KIT

The detection kit consists of fire detection links which detect the presence of fire or excessive heat (generated by fire) under the range hood, interconnecting cable and chain, corner pulleys and other components identified with Figure 4. Cable lengths are preassembled to fit the detection kit. Cable should not be lengthened or shortened except as specified for in this manual. Four (4) metal corner pulley assemblies are provided, however, for special installations, two (2) additional corner pulleys may be used.

DESCRIPTION	PARTS LIST QTY.
1-Cable, 1/16" Stainless Steel (P/N KB306)	1
2-Hook, S-Style (P/N KB341)	8
3-Pulley, Corner 90-AS-MC Assembly (P/N CPUL-KB9OAS)	2
4-Pulley, Rear 90-AS Assembly (P/N PUL-KB9OAS)	2
5-Link, Fusible (Electric) 165 F (P/N E165) *	2
Link, Fusible (Electric) 212 F (PIN E212) Standard	4
Link, Fusible (Electric) 280 F (P/N E280) *	4
Link, Fusible (Gas) 360 F (P/N G130) Standard	4
Link, Reusable (Electric) 160 F (P/N RLINKI-5720) *	4
Link, Reusable (Electric) 171 F (P/N RLINK-5720-171) *	4
Link Reusable (Electric) 205 F (P/N RLINK-5270-205) *	4
Link, Reusable (Electric) 220 F (PIN RLINK-5730-220) Standard	4
Link, Reusable (Electric) 261 F (P/N RLINK-5720-261) *	4
Link, Reusable (Electric) 280 F (P/N RLINK-5734-280) *	4
Link, Reusable (Electric) 357 F (P/N RLINK-5720-357) *	4
Link, Reusable (Gas) 370 F (PIN RLINK-5740) Standard	4
6-Nut, Cable (P/N CNUT-KB1 14)	1
7-Mounting Bracket, Detection Kit (P/N DKIT-BRKT)	2
8-Bolt 3/16" X 34" (P/N CBOLT 3/16" X 34") +	4
9-Washer, Locking #10 (P/N WSHR-34018C) +	4
10-Nut, Hex 10-24 (P/N 1024) +	4
11-Chain, 90 LB. (P/N CHAIN-96)	1
* Optional Component	
+ Supplied with Hardware Kit	

HARDWARE KIT COMPONENTS
(P/N 21C/DETEC/HDW KIT)

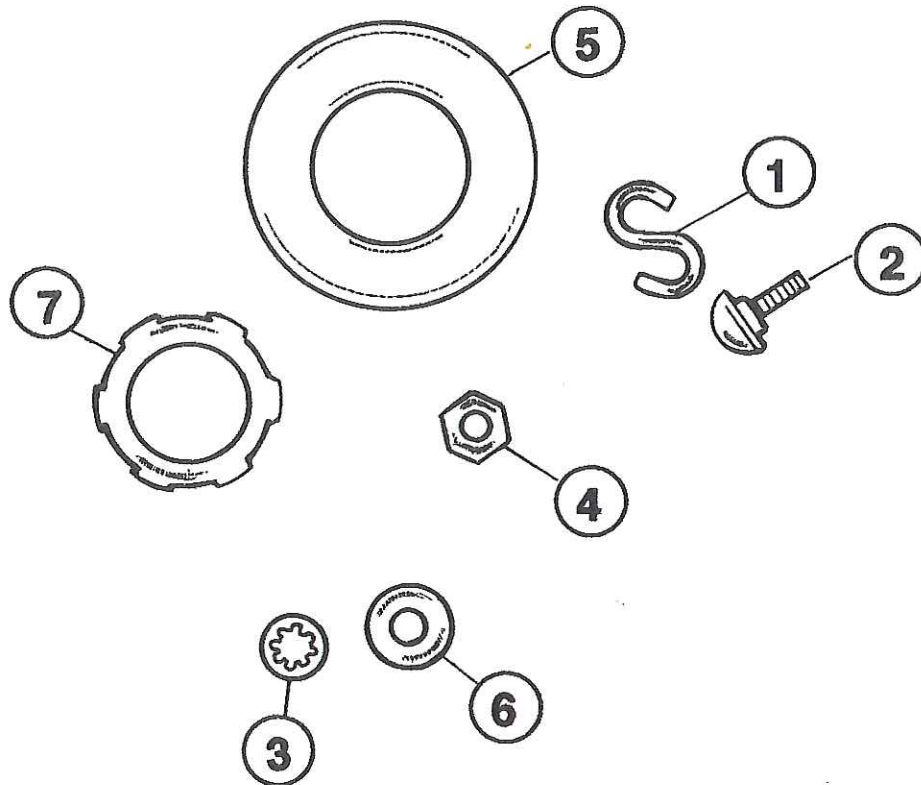

FIGURE 5

PARTS LIST

DESCRIPTION

DESCRIPTION	QTY.
1-S-Hooks (P/N KB341)	2
2-Carriage Bolt 3/16" x 1/2" (P/N CBOLT- 3/16 x W)	4
3-Washer, Lock Internal Tooth #10 (P/N WASHR-34018-C)	4
4-10-24 Hex Nut (P/N 1024)	4
5-1.5 OD PLTD. Flat Steel Washer (P/N FSW 1.5)	4
6-#10 Steel Cad Plated Washer (P/N FSW-10FW)	4
7-1/2" Locknut (P/N 21C/O5LN)	1

INSTALLATION INSTRUCTIONS

Before beginning installation of your Guardian unit, locate and identify each part (Figure 2, 3, 4 & 5). Turn off the electrical power supply to the kitchen range hood before boring holes. Wear approved safety goggles. Protect range top surface from falling debris. Comply with approved codes and ordinances when connecting gas or electric supply systems and fittings. Electrical wire and connections must conform to the rating of your appliances and equipment.

DO NOT USE ELECTRICAL EXTENSION CORDS FOR PERMANENT INSTALLATION!

ASSEMBLY TOOLS REQUIRED:

Two (2) Adjustable Wrenches, 8 or 10 inch
Pliers
Standard Screwdriver
Phillips Head Screwdriver
Electric Drill
3/16" Drill Bit
7/8" Hole Saw
Measuring Tape
Center Punch
Allen Wrench Set, including 1/8" and 7/64" Sizes

Note: To adjust pipe length, the following additional tools are required:

Hack Saw
Reaming Tool and File

With rangehood installed underneath cabinet, perform the following steps:

STEP 1 (Locate Holes)

Locate the best mounting location for the extinguisher and mounting bracket kit, either the left rear or right rear of the kitchen cabinet over the range hood. Mark the location of Hole C, Figure 7 (also, see Figures 8 and 9) in the rangehood. Mark the opposite rear corner pulley Hole D at approximately the same dimensions (Figure 7).

Locate the two nozzle/piping holes, A and B in the rangehood, so that the nozzles can be positioned between the front and rear burners (Figures 7, 8, and 13).

STEP 2 (Drill Holes)

Bore 3/16" pilot holes through rangehood and cabinet at the locations A, B, C and D identified in Step 1. Check the clearances around the filter elements, range hood lights, etc. Make sure ample room has been provided to adjust the cable tumbuckle. Then drill four (4) 7/8" at the pilot hole location through the cabinet bottom and range hood (Figures 7 and 8), for holes A, B, C and D.

STEP 3 (Rear Corner Pulley Installation)

Install rear corner pulley assemblies using flat washers and locknuts provided (Figure 10). Position is identified as Holes C and D in Figures 7 and 8.

NOTE: Looped end of the cable must correspond to the extinguishing and mounting bracket kit location — left or right side of the kitchen cabinet (See Figure 6).

STEP 4 (Front Corner Pulley Installation)

Position the front detection kit mounting brackets with the attached corner pulleys as close as possible to the front and outside edge of the range hood. Mark the location of the bolt holes (Figures 6 & 8).

NOTE: Corner pulleys shall be adjusted so that the cable does not touch the outer edges.

Drill four (4) 3/16" holes in the front face of the rangehood as shown in Figure 8. Attach the detection kit mounting brackets with the bolts, lock washers and nuts provided. (See Figure 8)

STEP 5 (Fire Detection Kit Installation)

A minimum of 1 1/2" clearance must be maintained between the nearest cable S-hook and the horizontal or vertical corner pulleys in the direction of cable movement when system is activated. Cable must be free to move 1 1/2" in the direction indicated without restriction. Angle the rear corner pulleys so that the cable enters and exits in the center of the pulley opening. (See Figure 6)

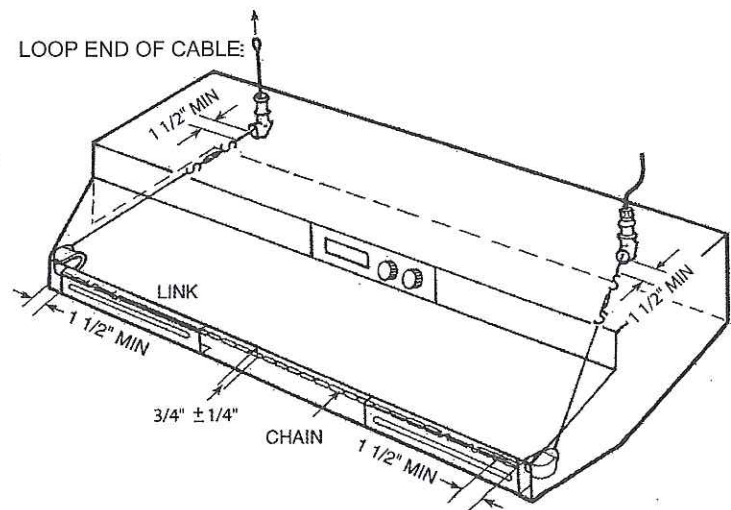
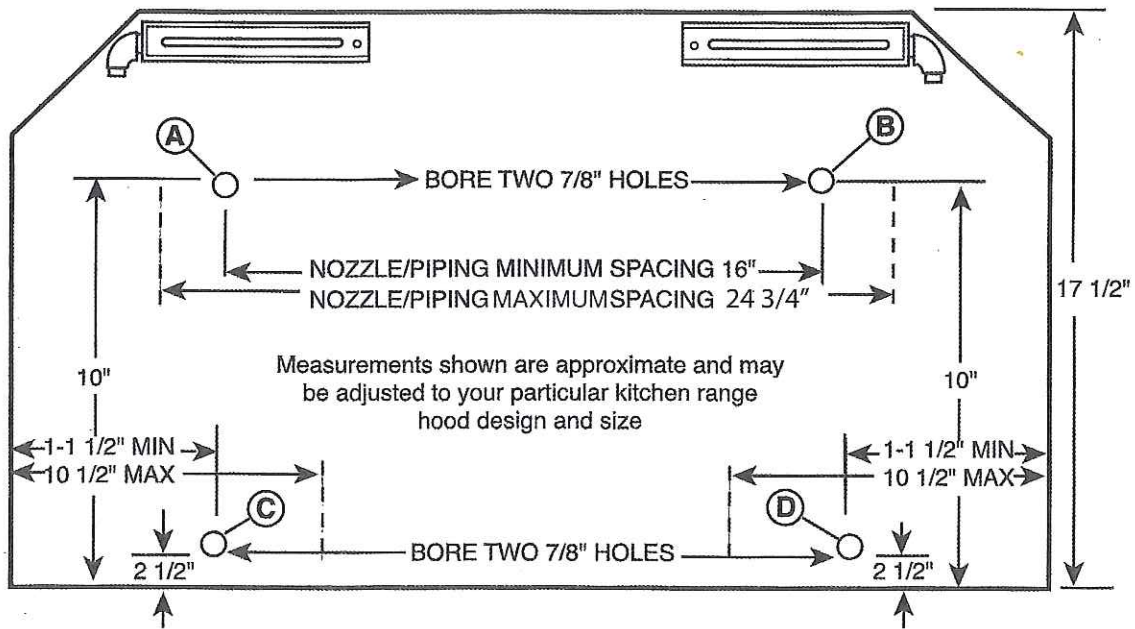

FIGURE 6

FIGURE 7

FRONT



NOTE: Front and rear corner pulley assemblies should be located so that individual fire detectors can be positioned directly over the kitchen range heating element. Corner pulleys shall be adjusted so that the cable does not touch the outer edges.

NOTE: Measurements shown are approximate and may be adjusted to your particular kitchen range hood design and size.

Pipe assemblies should be adjusted approximately 1/4" longer (1/8" per side) than the center line of the pipe holes to accommodate the 90° bend.

FIGURE 8

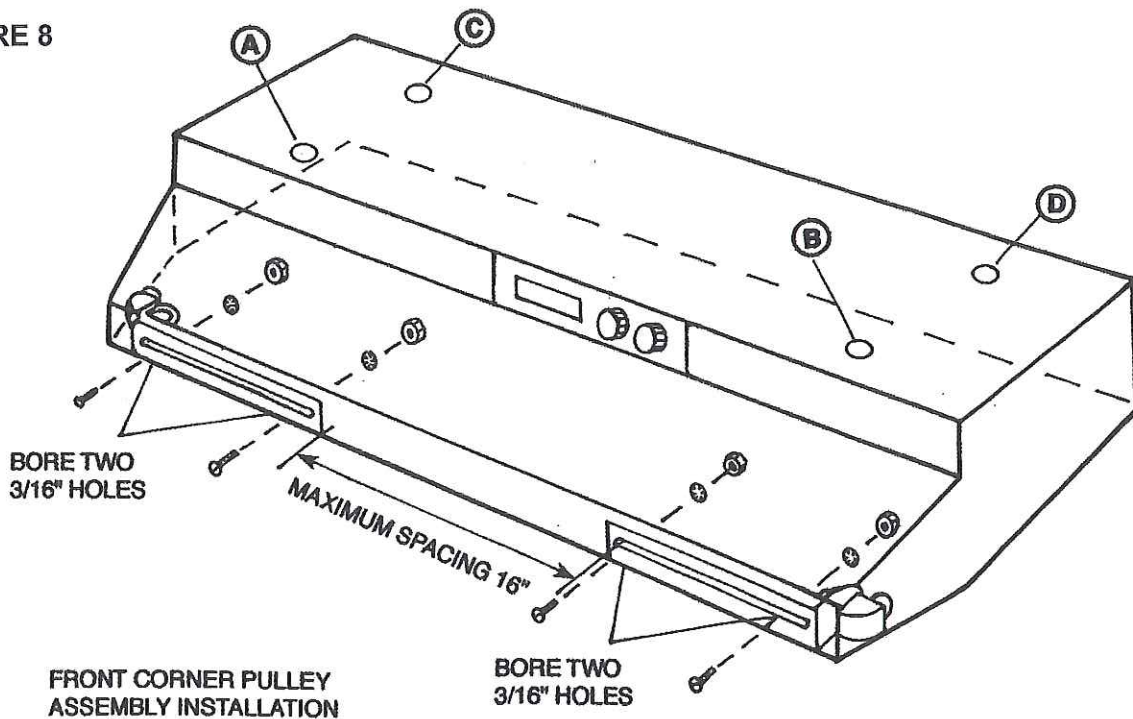

STEP 6 (Extinguisher Kit Mounting)

Insert the extinguisher and bracket kit in the desired location at the rear of the kitchen cabinet (left or right side). Attach with the mounting screws provided (Figure 9).

NOTE: Make sure the ball bearing wheel, cable guide and micro switch have been properly positioned to match up with the rear corner pulley assembly (left or right side mounting).

Spacer tabs are provided for proper positioning of the extinguisher bracket for cabinets with or without top or bottom header boards.

NOTE: The ball bearing wheel, cable guide and/or micro switch may be located on either the left or right side of the mounting bracket for ease of installation.

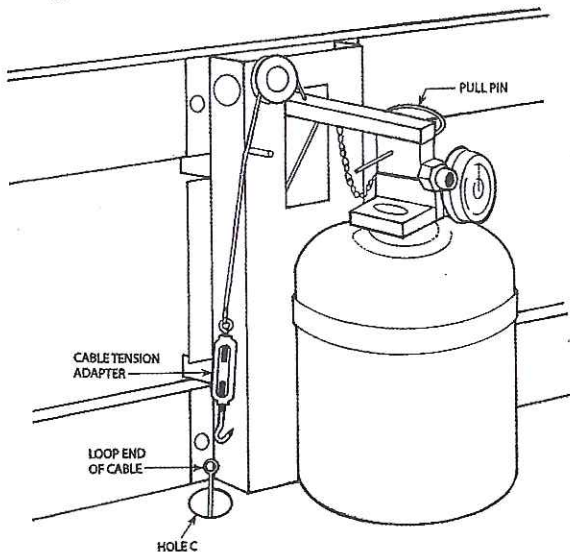

FIGURE 9

STEP 7 (Detection Kit Adjustments)

Place the looped end of the detection kit cable on the hook of the cable tension adjuster through Hole C (See Figure 9). Use an S-hook if necessary and make sure the turnbuckle is fully extended.

Adjust the detection kit chain between the two front fusible links so that the links are in the proper position (Figure 6 and Figure 12). After final adjustments have been made, excess chain should be removed.

Pull excess cable through the cable nut until all slack is removed and secure tightly with the set screw (See Figure 10). Make sure the fire detectors (fusible or reusable links) align according to Figures 6 and 12. If necessary, you may use extra S-hooks to adjust proper spacing, however, no more than two (2) S-hooks may be connected consecutively.

NOTE: When extra S-hooks are installed, they should be crimped tightly closed with pliers.

STEP 8 (Piping Kit Adjustments)

NOTE: Ferrules cannot be repositioned after tightening. Therefore, it is recommended that the piping assembly be loosely assembled and checked for proper fit before tightening the fittings.

Piping Kits are shipped pre-cut, however, if required, stainless steel tubing may be cut at either end to fit the installation requirements. Cut stainless steel tubing to fit the piping holes (Figures 7 and 8). Measure tubing 1/4" longer than the center line of the holes (1/8" longer per side) to accommodate the 90 bend. However, overall length (O.A.L.) for each tube section must not exceed the minimum or maximum dimensions listed in Figure 11. Tubing on each side of the compression tee should be cut in equal lengths so that the tee is centered between nozzles. When the tubing is cut, make certain all ends are reamed and cleaned of all burrs prior to installation. To ensure proper flow of wet agent through the tubing, it is important that the internal surfaces of tubing are free of any foreign matter. To preset ferrule, insert the tube end into the fitting until it butts against the shoulder and screw the nut down finger tight. All tube joints must be disassembled and inspected for proper make-up before final assembly. Reassemble for final installation by inserting the tube into the fitting body and wrench the nut down easily until a sudden increase in torque is evident. From this point turn the nut an additional 1/4 to 1/3 turn (1 1/2 to 2 wrench flats) to again spring the ferrule into place to seal against the tubing and the fitting body.

STEP 9 (Piping Kit installation)

Install piping into front Holes A and B (Figure 8) and secure with stauff clamps and screws provided. Attach the flexible hose swivel nut to the brass piping adaptor on the extinguisher. Place a wrench on the hex surface of the valve piping adaptor and a wrench on the hose swivel nut for tightening. **Do not attempt to tighten or remove the hose swivel nut without a wrench on the valve piping adaptor.** (See Figure 2, Item 10)

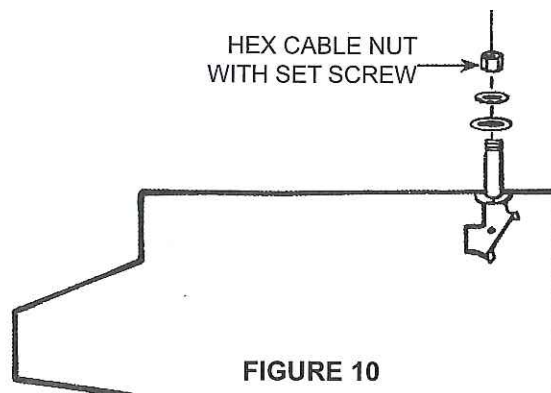

FIGURE 10

STEP 10 (Nozzle Attachment)

Attach appliance nozzles and swivel assemblies to the pipe protruding through the underside of the range hood. Loosen the locking nut on the swivel assemblies, aim and align nozzles pointing between burners, then tighten the nuts to lock the nozzles in place. See Figure 13 for aiming the appliance

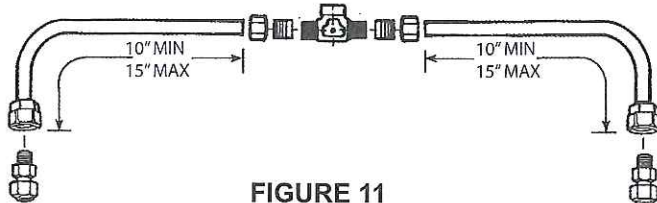

FIGURE 11

NOTE: All pipe cuts must be reamed and deburred before assembly.

STEP 11 (Arming System)

To arm your Guardian system, turn the cable tension adjuster until the cable is tensioned and the fire extinguisher handle moves slightly upward (about 1/4"). The safety pull pin should slide in and out freely. When properly adjusted, the cable tension will be 14-15 lbs. (See Figure 9).

CAUTION: Too much cable tension may rearrange the prepositioned link assembly. Too little cable tension may cause the Guardian to prematurely activate when you remove the safety pull pin.

NOTE: Do not remove the safety pull pin from the valve assembly until installation of the Guardian system is complete, including any optional accessories. To remove the safety pull pin, cut the plastic safety seal and pull the pin out completely.

THE GUARDIAN IS ARMED AFTER REMOVAL OF THE SAFETY PIN.

TARGET AREA FOR APPLIANCE NOZZLES

TARGET AREA FOR INSTALLATION OF FIRE DETECTION LINKS (TYPICAL TO MOST KITCHEN RANGES)

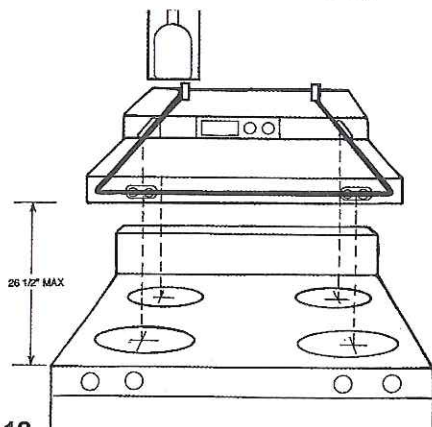
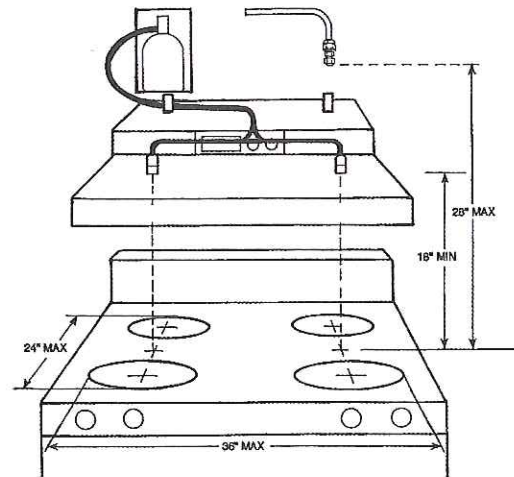

FIGURE 12

Center each fire detection link directly over each kitchen range heating element. Should the size and type of your kitchen range prevent centering, you may position a detection link no more than one (1) inch from the edge of a kitchen range element.

Distance from the detection links to the kitchen range top cooking elements shall not exceed 26 1/2" inches.

FAILURE TO FOLLOW THIS PROCEDURE MAY DELAY ACTIVATION OF THE GUARDIAN AND PREVENT EFFECTIVE EXTINGUISHING.



Aim appliance nozzles at the center point between the front and rear kitchen range heating elements. Distance from the appliance nozzles to the range top surface shall not be less than 18 inches or more than 28 inches.

FAILURE TO FOLLOW THESE PROCEDURES MAY RESULT IN INADEQUATE COVERAGE OF EXTINGUISHING AGENT OVER BURNER AREAS.

SHUTOFFS

ELECTRIC: Electrical Contactor: 1 20-volt coil AC operation for electric range 50 AMP (resistive), 2-pole type. (P/N 21C/KB54-3)
 Contactor Enclosure: Protective cover for 120-volt electric contactors. (P/N 21C/KB71)

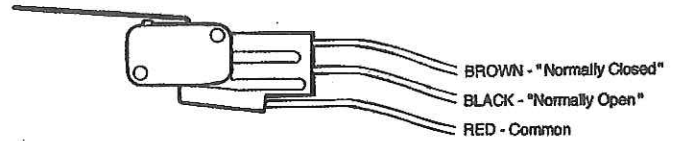
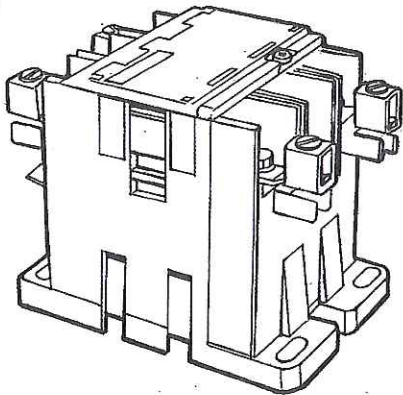

FIGURE 14



Wiring diagrams are provided as a guide to installing fuel shutoffs. All fuel shut-offs should be installed in accordance with the regulations and codes which apply in your locality.

WIRING INSTRUCTIONS

Instructions for wiring the required range top shut-off device and other electrically operated accessories are provided separately with each component. The micro switch (P/N PCLCD-2A) is factory installed on the mounting bracket. A conduit attachment hole for a 1/2" conduit fitting is provided for 120-volt wiring (see Figure 2). Micro switch wire leads are provided as follows (see Figure 15)

Red - Common connection, usually connected to electric power source

Brown - Normally closed, provides continuous electric current until the Guardian system is activated, at which time power is switched "off" from connected accessories.

Black - Normally open, no electric current will flow until the Guardian system is activated, at which time power is switched "on" to connected accessories.

Maximum electrical load rating for the micro switch is 21 AMP, 1 H.P. at 125-volt AC. Consult your GSSI representative for specific wiring instructions.

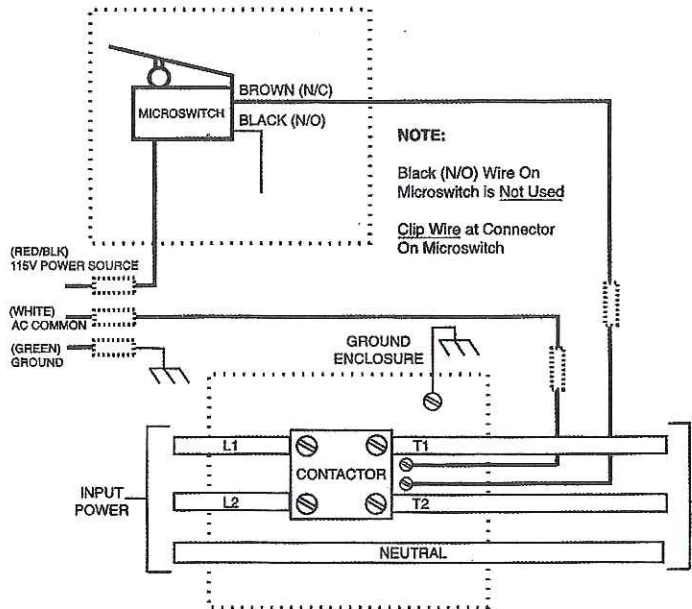

GAS: Pneumatic Gas Valve. (P/N 21 C/NM220606
Pneumatic gas valve assembly (complete with 8' stainless
steel hose) (P/N GSOAIP1 OOA).

APPLICATIONS AND LIMITATIONS

PNEUMATIC GAS VALVE: The pneumatic gas valve (See Figure 17) has been engineered to be installed in either a horizontal or vertical run of piping without affecting operation of the valve. Orientation of the valve in the vertical position, of course, would have no effect on its operations. Likewise, in the horizontal position, it can be oriented anywhere within a 360° rotation. The only limiting factors to be concerned with are locating the inlet feed port (See Figure 18) of the pilot line so that installation can be easily accomplished.

The valve should be located as close to the back wall (normally behind the range) as possible to permit the range itself to be positioned as close to the wall as possible. Connect the stainless hose to the piping assembly located in the cabinet above the range hood (See Figure 19).

Should the Guardian system be activated due to fire conditions or by accident, it is suggested, but not required, for the pneumatic valve to be cleaned before returning the system to service. As a minimum, when pushing the reset button, a visual inspection should be conducted. For complete cleaning instructions, see "Gas Valve Cleaning Procedure".

The pneumatic valve pilot consists of an inner Teflon tube 3/16" ID. X 1/4" O.D. with an outer sleeve covering of stainless steel wire mesh which reinforces and strengthens the inner tubing. Swivel fittings are provided on each end of tubing for ease of installation. Crushing or collapsing the inner tubing accidentally is nearly impossible. The maximum allowable radius permitted to be formed in this line without presenting any problem is a 2" radius.

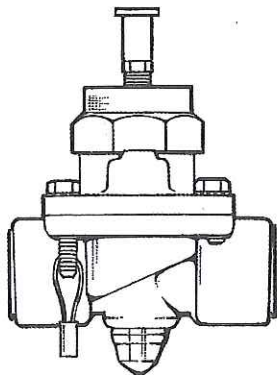

FIGURE 17

FIGURE 18

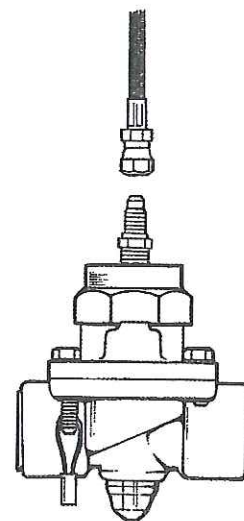
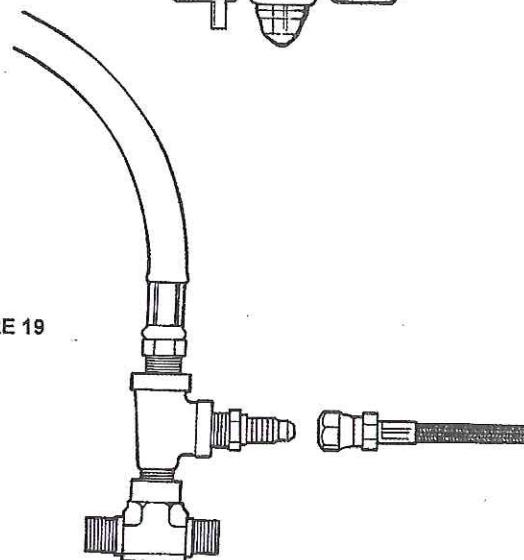

FIGURE 19



GAS VALVE CLEANING PROCEDURE

Close the gas service line shutoff, bleed the line pressure from the valve by opening the stove burner or by slowly removing the service line from the outlet side of the pneumatic valve and remove the top hex cover. Remove the diaphragm and O-ring seal from the top hex cover, being careful not to damage it during removal. Soak the diaphragm and seal in warm sudsy water until clean. (Do not use any chemical cleaning agents.) Inspect the diaphragm and seal for any sign of damage. If damaged, replace with authorized parts. Reassemble the diaphragm and O-ring seal in the proper place. Insure that the diaphragm is flat and not rolled up the side of the top hex cover. **CAUTION:** Be careful not to cross-thread when reinstalling the top hex cover. Torque the top hex cover to 175 inch pounds. **NOTE:** When unit is reinstalled, push the reset button to return the valve to service.

NOTE: Breaking seal on valve body voids warranty.

ACCESSORIES

Guardian Safety Solutions International offers a complete line of optional accessories and shutoff devices listed for use with the Guardian Model 1384-B. (Assembly and wiring instructions are provided with each optional accessory.) Consult your GSSI representative for current models available.

OPTIONAL AUDIBLE ALARM (P/N 21CIW3IT)

DESCRIPTION

Audible Alarm: 120-volt alarm to warn occupants when the Guardian is activated. (P/N 21CIW3IT)

OPTIONAL REMOTE MANUAL RELEASE (P/N 21C/PULL R800155)

APPLICATION AND LIMITATIONS

A remote manual release system (manual pull station) is available where local fire codes or circumstances require the capability to manually activate the range top extinguisher system. Manual activation of the system will cause the extinguisher unit to fully discharge extinguishing agent, shut off the range top burners and activate an alarm or other electrical accessory. Once activated, the automatic sequence cannot be interrupted.

The manual pull station is installed at a height not exceeding 60° from the floor and should be located in the path of exit. Avoid locating the manual pull station where the occupant would have to reach over the range top cooking elements to activate the system. (Some jurisdictions require certain distances.) Only Manual Pull Station (P/N 21C/PULL R80015) shall be used.

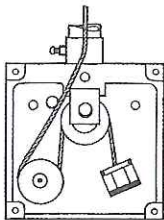

FIGURE 20

INSTALLATION INSTRUCTIONS

NOTE: Before starting, reinstall safety pull pin in valve assembly (See Step 11 Procedure).

1. Determine the best location for the manual pull station box. The location must be accessible with a maximum of seven (7) additional corner pulleys and a maximum of twenty-nine feet, seven inches (29' 7") of conduit. The manual pull station is usually located opposite the extinguisher kit. Adjust the extinguisher kit mounting accordingly — on the right or left side of the range hood (see Figure 22).
2. Attach a corner pulley to the rear corner pulley piping opposite the extinguisher kit. The manual release system cable will be an extension of the detection kit cable. The manual pull station replaces the cable nut.

3. Install conduit and additional corner pulleys as necessary to reach the manual pull station box. All cable must be fully enclosed in rigid conduit from the detection kit rear pulley to the manual pull station box (conduit must be provided by installer). A looped end on the cable attaches to the S hook between the last link and rear corner pulley assembly.

NOTE: Make sure both cable ends are crimped and all "5" hooks closed. Total length of conduit (all sections) must not exceed (29' 7") feet. Total number of corner pulleys added to the detection kit must not exceed seven (7).

4. Remove the manual pull station cover plate and pulley assembly. Route the cable around the floating pulley and mount pulley assembly in the pull station box. Secure the cable end with the cable nut provided. (See Figure 20)

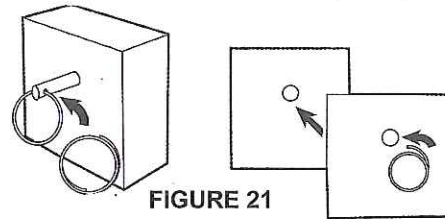

FIGURE 21

NOTE: See Installation Step 6 (Detection Kit Adjustments), Page 10 in this manual.

5. Insert the pull pin to lock the floating pulley in position before attaching the pull pin ring or replacing the cover plate. Adjust the cable length to properly align the fire detectors and tighten the cable nut allen set screw.
6. After the extinguisher system installation is complete and final adjustments have been made, replace the manual pull station cover plate, insert the pull ring into the pull pin and install the tamper seal. (See Figure 21)

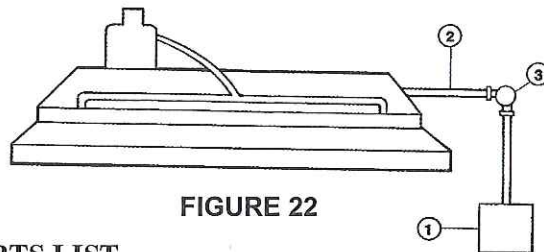

FIGURE 22

PARTS LIST

DESCRIPTION	QUANTITY
1- Remote manual release assembly (P/N R8001 55)	1
2- 1/2" Conduit (Supplied by installer)	(29' 7") max
3- Corner pulley	(7) max (P/N KB9OAS)

TROUBLE SHOOTING POINTS

PROBLEM	CAUSE	CORRECTION
Low Pressure No Pressure	Inadequate cable tension Leak Weak tension spring Cable slipping	Retention cable Recharge/leak test Replacing spring Tighten machine screw attached to hex nut
Corner pulley not secure	Loose screw on corner pulley Loose fitting on corner pulley	Tighten Tighten
Fire extinguisher mounting bracket not secure	Support screws loose	Tighten or replace screws
Fire detection not positioned over range top elements	Worn tension spring cable slipping	Replace spring Readjust cable and replace or tighten machine screw fitted with hex nut
Appliance nozzle not aimed at range top center	Range repositioned loose adjustment screw(s)	Reposition Range Re-aim nozzle and tighten adjustment screw(s)

SEE ENCLOSED WARRANTY CARD



Guardian Safety Solutions International, Inc.

8701 John Carpenter Freeway Suite 230 Dallas, Texas 75247

Fax: (972) 594 - 7826

Phone: (972) 252 - 6201

Toll Free: (800) 786 - 2178

www.theguardiansolution.com